

SA2580 Panther

2.5" SATA Solid State Drive



MEMTECH

- 2.5" drive low profile form-factor
- 4 to 64 Gbyte capacity under 9.5mm
- Proprietary IC Tower Stacking Technology
- Full -40°C to +85°C industrial temperature range
- 1.5Gbit Serial ATA (SATA) interface
- 150 Mbyte/sec interface transfer speeds
- Up to 40 Mbyte/sec sustained Read/Write performance
- Powerful ECC and proprietary wear leveling for exceptional data reliability
- 5 volt, low power operation
- Completely solid state - no moving parts
- 1500G, 0.5ms operating shock
- 16.3G operating random vibration
- 0.1 millisecond random access time
- 8 year product warranty
- Intelligent destructive and non-destructive sanitization



The SA2580 Panther series of solid-state flash drives are a 1.5Gbit Serial ATA compliant memory module offered in an extremely low profile 2.5 inch drive form-factor. The drive is completely solid state, with no moving parts. This contributes to the unit's exceptional ruggedness and wide operating temperature range; with no moving parts, there is no mechanism for mechanical wear-out. The drive fully complies with the Serial ATA 1.0 specification and therefore requires no special drivers or flash file managers to interface to the drive. This makes the drive a virtual drop in replacement for standard rotating media but with superior performance, ruggedness and reliability.

The primary storage media in the drive is sector-erasable NAND E²PROMs (Flash). Using these SLC devices, Memtech is able to deliver up to 64 Gbytes of uncompressed, non-volatile solid-state storage in an extremely small, rugged form-factor. The Serial ATA (SATA) interface supports 150-Mbyte per second burst throughputs, and with an access time for the drive under 0.1 milliseconds, thousands of transactions can occur per second. In addition to the extremely high IO capability of the drive, the sustained read and write performance is exceptional at up to 40 Mbytes/sec.

The Panther, with its high-capacity and high-throughput, is a rugged memory and mass storage solution ideal for mission-critical systems in a variety of industries. Applications include data recorders, image exploitation computers, navigation systems, oil pipeline monitors, scientific equipment, RAID systems, financial transaction processing systems, media server equipment, and communications equipment.



MEMTECH

The SA2580 is available now in standard capacities ranging from 4 to 64 Gbytes, all in the same, 9.5mm low profile solution. Every drive is subjected to Memtech's exacting EnduroTest™ in which each drive is fully tested under environmental and voltage extremes to guarantee data integrity under even the harshest conditions, and to ensure full functionality out of the box.

The SA2580 may be mounted in any orientation. Sixteen mounting holes are available: eight on the bottom and eight on the sides. All holes are tapped 3mm with a maximum penetration of 4mm.

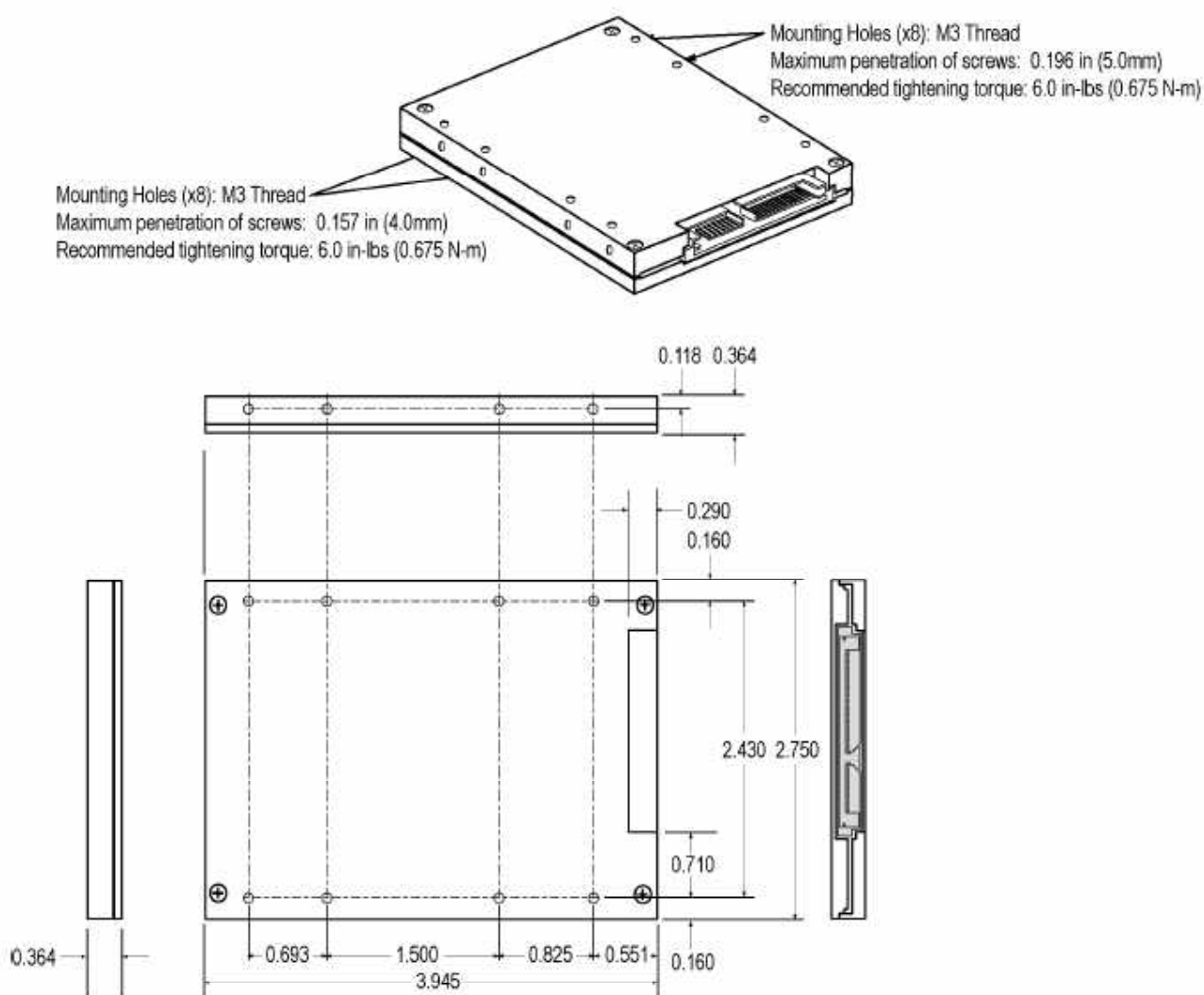



SPECIFICATIONS*

Interface

Compatibility	ATA/ATAPI-7 compliant SATA 1.0
Physical Capacity	4 to 64 Gbytes
Physical Sector Size	512 bytes
SMART (Self-Monitoring, Analysis and Reporting Technology) compliant	

Performance

Average Access	0.1 ms
Track/Track Access	0.1 ms
Burst Transfers	150 Mbytes/sec
Sustained Data Rate	
AT2582	20 Mbytes/sec
AT2583	30 Mbytes/sec
AT2584	40 Mbytes/sec

Environmental

Operating Temperature Range	
Commercial	0° to +70°C
Extended	-20° to +75°C
Industrial	-40° to +85°C
Storage Temperature	-55° to +125°C
Shock - operating	1500G, 0.5ms half sine
Vibration - operating	16.3G, random
Altitude	80,000 feet
Airflow	None required
Humidity	5% to 95% NC
Safety	CSA File LR114427
EMC	EN55022 and EN50024

Reliability

Proprietary wear-leveling and remapping architecture	
Endurance	
erase/write endurance	8 million cycles
read endurance	unlimited
data Integrity	10 years
ECC	32-bit Reed-Solomon

Power Requirements

Voltage	5V +/- 5%
Current Draw – 8 Gbyte model	
Read/Write	502 mA
Erase/Fill	600 mA
Current Draw – 16 Gbyte model	
Read/Write	431 mA
Erase/Fill	583 mA
Current Draw – 32 Gbyte model	
Read/Write	431 mA
Erase/Fill	741 mA

Mechanical

Length	3.94" (100.2 mm)
Width	2.75" (69.8 mm)
Height	0.37" (9.5 mm)
Cable Interface	7-pin signal segment 15-pin power segment
Weight	varies by size

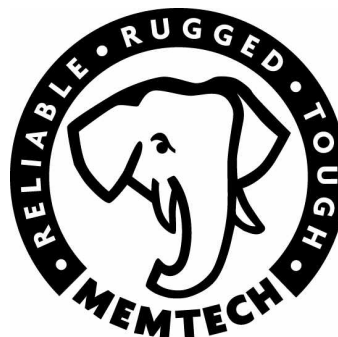

*Specifications subject to change without notice.

7628 Las Positas Road
Livermore, CA 94551 USA
<http://www.memtech.com>

Ver 1.2

phone (925) 294-8483
toll free (800) 445-5511
fax (925) 294-5920