

**AT2500 Tusker
2.5" IDE Solid State Flash Drive**

User Guide

**153219-001
Revision 4.3
October 31, 2001**

**Memtech SSD Corporation
7628 Las Positas Road
Livermore, CA 94550
(925)294-8483
(800)445-5511
www.memtech.com**



Table of Contents

1. HIGHLIGHTS	3
2. INTRODUCTION	3
3. INSTALLATION	4
3.1 PROCEDURE	4
3.2 JUMPERS	6
3.3 IDE INTERFACE	9
4. OPERATION	11
4.1 ACTIVE REMAP™ AND WRITE LIMITATIONS	11
4.2 ECC	11
4.3 POWER	12
4.4 TROUBLE SHOOTING GUIDE	13
5. MAINTENANCE	13
6. SPECIFICATIONS	14
6.1 INTERFACE	14
6.2 PERFORMANCE	14
6.3 ENVIRONMENTAL	14
6.4 POWER REQUIREMENTS	14
6.5 MECHANICAL	15
6.6 RELIABILITY	15
7. APPENDIX	17
7.1 CONTACT INFORMATION	17
7.2 ATA SPECIFICATION INFORMATION	17
7.3 WARRANTY	17



1. HIGHLIGHTS

- 3072 Mbyte capacity
- Full -40°C to +85°C operating temperature range
- 5 volt, low power operation
- Completely solid state - no moving parts and no batteries
- Extremely Rugged - 1000G operating shock, 15G operating vibration
- 2.5" drive form factor with a 44 pin, 2mm IDE interface
- 11 byte ECC and Active Remap™ for exceptional data reliability
- 0.3 millisecond access time
- 2.0 Mbyte/second sustained Read throughput
- 650 Kbyte/second sustained Write throughput
- 128 Kbyte SRAM buffer
- Nonvolatile NAND E²PROM with 10 year data retention
- EMC and CSA Safety Compliant

2. INTRODUCTION

The AT2500 series is a new line of 100% compatible IDE solid state drives in a 2.5 inch drive format. It is completely solid state, with no moving parts. This accounts for the units exceptional ruggedness and wide operating temperature range.

Sector Erasable NAND E²PROM (Flash) in 128, 256 and 512 Mbit configurations are used to provide up to 3072 Mbytes of nonvolatile, solid state storage in an extremely small, rugged form factor. The drive is 100% IDE compatible and requires no special drivers to operate. It is essentially a drop in replacement for standard rotating media.

The IDE interface is implemented using a commercially available IDE controller with 24 mAmp drivers, a 128 Kbyte SRAM buffer, and an 11-byte Reed-Solomon error detection and on-the-fly correction mechanism that greatly improves data reliability over other standard solid state drives. The ECC circuitry, in conjunction with Memtech's proprietary Active Remap™ technology, makes for a virtually bulletproof medium for data retention.

The drive is available in a number of standard capacities ranging from 16 to 3072 Mbytes. Please contact the factory with your capacity requirements. Disk compression utilities may be used to effectively double the usable capacity of the drive.

Each drive is fully tested under environmental and voltage extremes, to guarantee data integrity in even the harshest conditions.



3. INSTALLATION

3.1 PROCEDURE

3.1.1 ESD PRECAUTIONS

Static electricity kills... electronics! Before handling the AT2500, please observe the following precautions to avoid ESD damage to the unit:

- Keep the drive in its shielded bag until ready to install.
- Ground yourself by touching a grounded chassis frame of the computer, or use a grounded wrist strap before and during the installation process.
- Do not touch the exposed drive electronics or connectors. Always handle the drive by the edges or mounting rails.

3.1.2 CONFIGURATION

Configure the drive using the jumper diagrams given in Section 3.2. The drive is shipped configured for a single drive system or as the master in a two drive system. Change the configuration as required. Never attempt to change the jumpers while the drive is plugged in and the computer is on.

3.1.3 CABLE

With the computer off, attach the 44-pin 2mm cable connector to the 2mm connector on the drive. Note pin 1 orientation and alignment. Care should be taken when installing the cable, as misalignment can permanently damage the drive interface. No power cable is required as power is supplied by the 2mm ribbon cable connector.

3.1.4 MOUNTING

The AT2500 may be mounted in any orientation. Eight mounting holes are available: four on the bottom and four on the sides. All holes are threaded 4-40, with a maximum penetration of 0.25 inches.

The diagram given below is for a 768 Mbyte drive. Drives with capacities of 192 Mbytes or less will be only 0.575" tall. All other dimensions remain identical.

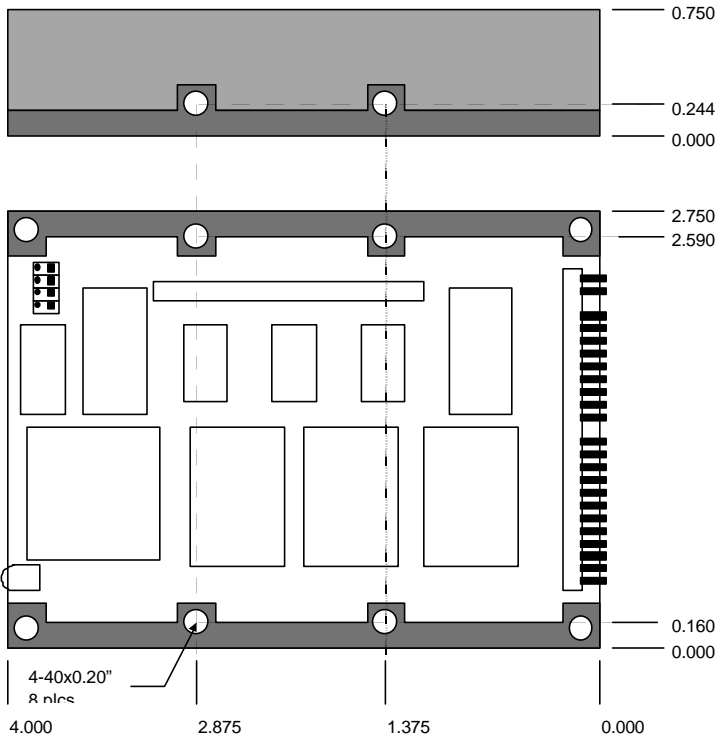

3.1.5 COMPUTER SETUP

To be recognized by the computer, the drive translation information must typically be entered into the System Setup or CMOS Setup utility. For non-PC compatible computers, this may not apply. The AT2500 supports automatic configuration if offered by the BIOS. Automatic CHS translation and LBA mode is supported.



3.1.6 PARTITION

The drive must be partitioned using the system's FDISK utility. For operating systems other than DOS, please refer to your OS operating guides. Note that changing the partition information will erase all data currently on the drive. Refer to your OS manual for information regarding partitioning a hard disk.

3.1.7 FORMAT

The AT2500 is low-level formatted at the factory, which establishes the 512 byte sector size. A high-level format is required after the partition has been established on the drive. Refer to your OS manual for information regarding hard disk drive format procedures.

3.2 JUMPERS

The following diagram illustrates the locations of the jumpers on the AT2500 controller card. The jumpers control the master slave configuration, cable selection, drive write protection, and other factory related functions.

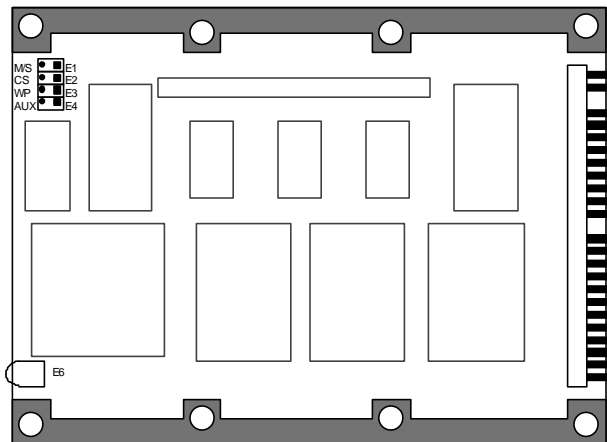



3.2.1 MASTER/SLAVE

E1 allows the drive to be configured as either drive C: (Master) or drive D: (Slave). This jumper is a 2 pin right angle header on 2mm centers. Leaving the pins open configures the drive as the master, drive C:.

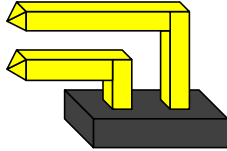
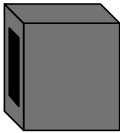

E1: Configured for normal operation -- jumper off

Connecting the pins forces the drive to drive D:, the slave.

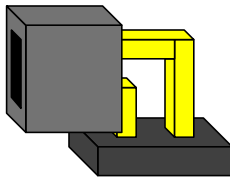

E1: Configured as second drive -- jumper on

This location is factory shipped with no jumper, configuring the drive as the master drive.

3.2.2 CABLE SELECT

Jumper E2 can be used to let the IDE Cable Select signal select the drive configuration as either the master or slave device. Shorting the pins on E2 enables the Cable Select feature. Leaving the pins unconnected disables the Cable Select feature. The drive is factory shipped with these pins open.

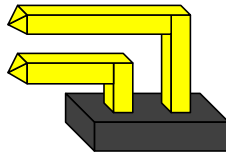
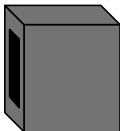

E2: Configured for normal operation -- jumper off

3.2.3 WRITE PROTECT

Jumper E3 is used to write protect the drive, in the situation a read only function is desired. This jumper is normally OFF. Installing a jumper on E3 inhibits all further writes to the drive, while read accesses occur as normal.

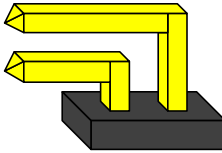
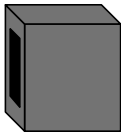

E3: Configured for normal operation -- jumper off

3.2.4 AUX3

Jumper E4 is used for factory test functions only, and should always be left open.

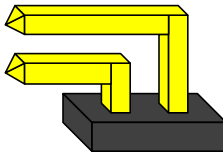
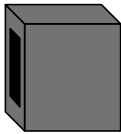

E4: Configured for normal operation -- jumper off

3.2.5 SPECIAL NOTE

To provide the user with ready access to a 2mm jumper, pin 2 of E3 and pin 2 of E4 (topmost pins) can be used to store an extra jumper with no adverse effects to the system. See diagram below:

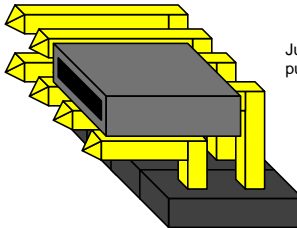

Jumper installed for storage purposes. E3-2 to E4-2



3.3 IDE INTERFACE

The AT2500 uses a 44-pin right angle 2mm connector mounted on the controller PCB to create both a power and signal connection to the host. Maximum cable length is 18 inches. Recommended cable length is 12 inches or less, especially if an advanced PIO or DMA transfer mode is to be used. The recommended mating socket connector is 3M 152244-003-GG or equivalent.

3.3.1 IDE ADAPTER

An adapter converting the 2mm IDE connector to a standard 40 pin 0.100" IDE connector is available from the factory. Order part number 153264-002. The adapter converts the signals from the 2mm connector on the drive to a 0.100" connector. Power arrives via a 4-pin Amp power header (EI series) identical to the connector used to supply power to 3.5 inch floppy drives. To convert the 4-pin Amp power connector to a standard 4-pin AT power connector, request the ATA power cable adapter, part number 153273-002.

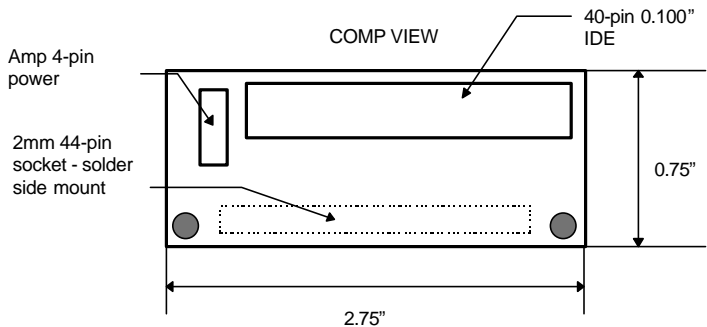

3.3.2 IDE CONNECTOR PHYSICAL ORIENTATION

The diagram below depicts connector orientation and location.

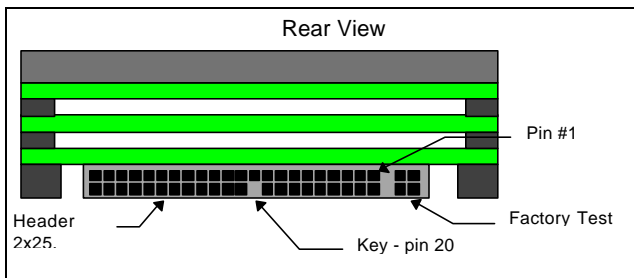



3.3.3 IDE CONNECTOR PINOUT

The following table depicts the 44-pin, 2mm signal cable interface pinout.

PIN	SIGNAL	PIN	SIGNAL
1	RESET-	2	GND
3	DATA7	4	DATA8
5	DATA6	6	DATA9
7	DATA5	8	DATA10
9	DATA4	10	DATA11
11	DATA3	12	DATA12
13	DATA2	14	DATA13
15	DATA1	16	DATA14
17	DATA0	18	DATA15
19	GND	20	KEY (NO PIN)
21	DRQ	22	GND
23	IOW-	24	GND
25	IOR-	26	GND
27	IOCHRDY	28	CSEL
29	DACK-	30	GND
31	IRQ	32	IOCS16-
33	ADDR1	34	PDIAG-
35	ADDR0	36	ADDR2
37	CS0-	38	CS1-
39	DASP-	40	GND
41	+5VOLTS	42	+5VOLTS
43	GND	44	RESERVED



4. OPERATION

4.1 ACTIVE REMAP™ AND WRITE LIMITATIONS

Unlike mechanical drives, wherein the wear-out mechanism lies with starting and stopping the platters and the rotation of the spindle motors, the wear-out mechanism for the AT2500 resides in writing to the NAND E²PROM. Writing the memories requires that electrons be first removed from, and then trapped on the floating gate in each cell using Fowler-Nordheim tunneling techniques. This process is inherently harsh on the oxide layer isolating the gate from the silicon substrate in the device, and establishes the 1 million write cycle endurance of each cell in a device.

To overcome this limitation, the AT2500 has been designed with Active Remap™, which, on a detected cell failure, moves the entire failing block to a reserved location, and maps the failing block out of active memory. This process is automatic and invisible to the user.

Limiting the number and frequency of the writes to the drive is the key to extending drive life. Use of the drive as a virtual memory storage element in an environment such as Microsoft Windows®, though supported, is not recommended, due to the volume of the writes initiated by this process. It is recommended that, in such an environment, the virtual memory operation be disabled so that program execution remains in DRAM, or the virtual memory target be moved to a different device.

Reading the NAND E²PROM has no adverse effects on the storage cells or oxide layers, and is therefore unlimited.

4.2 ECC

The NRZ data interface used by the IDE controller implements an 88-bit Reed-Solomon ECC polynomial, capable of correcting a single, 11-bit error burst on-the-fly, and detecting up to three 11-bit error bursts.

An extensive retry algorithm is implemented on the AT2500, so that single event disturbances such as ESD can be readily overcome. Probability of miscorrection is approximately 10^{-20} per bit corrected for a 512 byte field.



4.3 POWER

4.3.1 POWER DOWN

Whenever possible, do not power down the computer during a write command sequence to any mass storage device. This includes during the normal operation of the drive, and with the use of disk cache programs such as Microsoft® SmartDrive. If a write routine must be interrupted, use the push button reset or a soft reset. Powering down the AT2500 while it is being written may cause an incomplete write sequence, and leave as many as 16 sectors with an Address Mark Found Error or Uncorrectable Errors. DOS will report these with a message "Error Reading Drive X:", with X: being the AT2500 drive.

4.3.2 POWER SUPPLY

The AT2500 voltage requirement is specified at +5 volts, +/- 5% on the drive itself. Operation outside of these limits is not guaranteed. Note that the drive will "operate" down to 4.5 volts, but reliability issues such as Uncorrectable Errors or invalid data reads may occur. An on board voltage monitor will inhibit writes when the supply voltage falls below 4.70 volts, thus preserving data integrity on the drive.

4.3.3 POWER ROUTING

To avoid "glitches" or noise on the Vcc and ground lines, power in the system should be routed so that all peripherals are sourced from the power supply in a star configuration, as opposed to routing a single continuous supply line to each device in the system as in daisy chaining. Routing power in the star configuration, as is done on most desktop PCs, will minimize the effect on one device's current draw on another device. This is key to maintaining data integrity on the AT2500. See diagrams below.

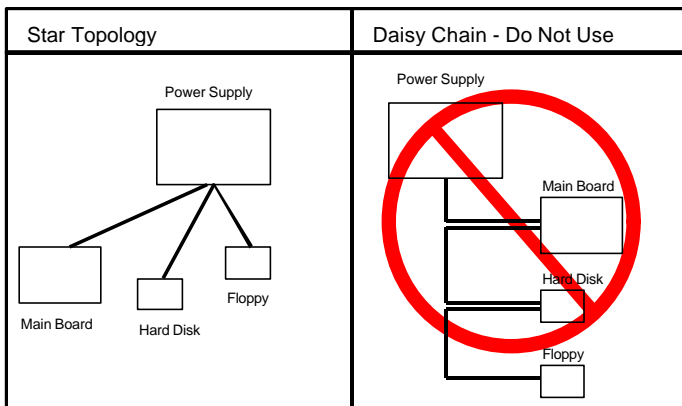



4.4 TROUBLE SHOOTING GUIDE

4.4.1 SELF-TEST DIAGNOSTIC CODES

The AT2500 has been designed to emit blink codes via the BUSY LED in the event of a low-level or catastrophic failure. A blink code of five would be defined as five fast blinks, a pause with no blinks, and a repeat of the process. The drive will not respond to commands or a soft reset when in this state. Only a power down or hard reset will clear the drive state and restart internal diagnostics.

Blink codes and their associated failure mechanisms are defined below. In the event a blink code is encountered, contact the factory for further assistance.

Number of Blinks	Error
2	ROM Firmware Checksum error
3	ASIC initialization error
4	SRAM Test failed
5	IDE buffer failure
6	IDE controller error
7	NRZ data path error

4.4.2 UNCORRECTABLE ERRORS

If a drive has been subjected to a power down during a write command, or as been run under marginal or dirty power conditions, uncorrectable errors may be introduced into the media. This may result in data read errors, a corrupted FAT table entry or directory, or an invalid boot partition or partition table. Microsoft® Scandisk or Norton Disk Doctor™ will successfully correct FAT table problems and partition table errors, but should not be allowed to mark a sector in the data area as bad. On a rewrite to a data sector with uncorrectable errors, all synchronization and ECC codes will be rewritten and the error will be eliminated.

5. MAINTENANCE

No maintenance is required during the normal use of this drive.

If data is to be archived for long periods of time (> 10 years), it is recommended that the data on the drive be refreshed every 5 to 10 years. The manufacturer of the NAND E²PROM devices will only guarantee data integrity for a period of 10 years. Programs such as Norton Speedisk®, which reallocates all sectors on the drive, or Microsoft® Scandisk, which writes and reads every sector on the disk during its surface test, achieve this end very well.



6. SPECIFICATIONS

6.1 INTERFACE

IDE Compatibility	X3T10 2008D, Rev. 6
IDE Drive Number	Drive 0 or 1
Physical Capacity	3072 Mbytes
Physical Sector Size	512 bytes

6.2 PERFORMANCE

Average Access	0.3 ms
Track/Track Access	0.3 ms
Onboard Cache	128 Kbytes
Read Transfer Rate	2.0 Mbytes/sec sustained
Write Transfer Rate	650 Kbytes/sec sustained
Burst Transfers	8.0 Mbytes/sec

6.3 ENVIRONMENTAL

Commercial Temperature Range	
Operating	0° to 70° C
Storage	-45° C to 125° C
Extended Temperature Range (E)	
Operating	-20° C to 75° C
Storage	-45° C to 125° C
Industrial Temperature Range (I)	
Operating	-40° to 85° C
Storage	-55° to 125° C
Shock - operating	1000G, half sine (target)
Vibration - operating	15G Random (target)
Airflow	None required
Humidity	5% to 95% NC (target)

6.4 POWER REQUIREMENTS

Voltage	5V +/- 5%
Current	AT2500-3072
Idle	10 mA
Read	210 mA
Write	225 mA



6.5 MECHANICAL

Length	4.00 inches (102 mm)
Width	2.75 inches (70 mm)
Height - > 192 Mbytes	0.75 inches (19 mm)
Height - ≤ 192 Mbytes	0.57 inches (15 mm)
Cable Interface	44-pin, 2mm
Max. Cable Length	18 inches (457 mm)
Rec. Cable Length	12 inches (305 mm)
Weight (3072 Mbytes)	5.8 oz (165 g)
Weight (768 Mbytes)	4.2 oz (120 g)

6.6 RELIABILITY

6.6.1 ERROR RATE

The ECC error rate for the AT2500 is <1 in 10^{14} bits read

6.6.2 MEMORY CELL ENDURANCE

1,000,000 writes per block minimum (excluding Active Remap™)

6.6.3 MTBF

The MTBF for the AT2500 has been calculated per MIL-HDBK-217F for varying environmental conditions. Example results are listed below:

A. Harsh

Capacity = 24 Mbyte
Temperature = 60°C
Mounting = Ground Mobile
MTBF = 128k hours

B. Benign

Capacity = 24 Mbyte
Temperature = 25°C
Mounting = Ground Fixed
MTBF = 629k hours

6.6.4 ENDURANCE

Calculated using the following parameters:

- 1,000,000 cycle cell write endurance
- 1 Kbyte write every 10 seconds
- 96Mbyte drive size
- Active Remap™ enabled

MTBF = 250K hours, or 28 years



The above calculations assume a worst case scenario wherein a single location is written repeatedly. When writes are spread across many cells, as is the case for a typical drive application, endurance will naturally improve.

Note: Those specifications listed herein as "Target" are not yet verified, and are provided as an indicator of projected performance values. Specifications subject to change without notice.



7. APPENDIX

7.1 CONTACT INFORMATION

For Technical Support or Warranty Repair information, please contact Memtech at:

7628 Las Positas Road
Livermore, CA 94550 U.S.A.
Phone: (925) 294-8483
Fax: (925) 294-5920
Email: Info@memtech.com

7.2 ATA SPECIFICATION INFORMATION

Information regarding the ATA-3 specification may be obtained from the following locations:

AT-Attachment Document Distribution
Global Engineering
15 Inverness Way East
Englewood, Co. 80112-5704
Phone: (303) 792-2181 or (800) 854-7179
Fax: (303) 792-2192

ATA Anonymous FTP Site
fission.dt.wdc.com
ATA3 directory is: "/pub/standards/ata/ata-3"

7.3 LIMITED LIFETIME WARRANTY

Memtech warrants your AT2500 against defects in material and workmanship for the life of the drive. The warranty is void in the case of misuse, accident, alteration, improper installation, misapplication or the result of unauthorized service or repair.

The implied warranties of merchantability and fitness for a particular purpose, and all other warranties, expressed or implied, except as set forth in this warranty, shall not apply to the products delivered.

In no event shall Memtech be liable for any lost profits, lost savings or other incidental or consequential damages arising out of the use of, or inability to use, this product.

BEFORE RETURNING PRODUCT, A RETURN MATERIAL AUTHORIZATION (RMA) MUST BE OBTAINED FROM MEMTECH.

Product shall be returned to Memtech with shipping prepaid. If the product fails to conform and warranty repair is necessary, Memtech will reimburse customer for the transportation charges incurred.